



STAINLESS STEEL INDUSTRIAL FLOOR DRAINS & CHANNELS

www.ozflow.com.au

OzFlow

OzFlow combines over 30 years of experience in developing and introducing innovative building and construction solutions with more than 70 years of German design and manufacturing expertise to bring smart, strong, hygienic and low maintenance industrial stainless steel drainage solutions to the market.

OzFlow's stainless steel industrial drainage products have been designed to meet the specific requirements of the local markets and are manufactured exclusively by Wiedemann GmbH in Germany.

For more than 70 years Wiedemann has been providing perfection in stainless steel, designing and supplying products for food and beverage facilities around the world including Europe, UK, USA, Japan and others.

Wiedemann manufacturing comprises of over 9,500 square metres of floor space, more than 200 employees, CAD, punching, laser cutting, welding and warehousing.

Wiedemann maintains ISO 9001 and numerous other international approvals and certifications

Quality and hygiene are assured with WaterMark and HACCP International certifications as well as Sydney Water and SA Water approvals

OzFlow stainless steel industrial floor drains and channels are manufactured from 1.4571 (AISI 316Ti) or 1.4301 (AISI 304) materials.

All OzFlow stainless steel drainage products are cleaned and treated following manufacture to ensure the highest levels of corrosion resistance.

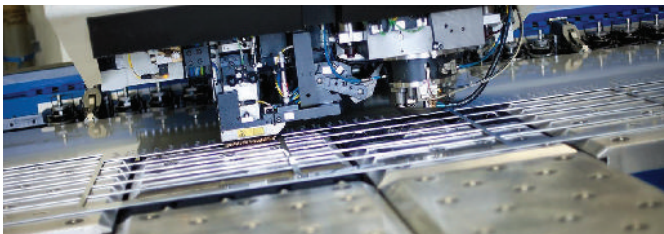

INDUSTRIAL FLOOR DRAINS

Solid Stainless Steel Rims for Round and Square Designs

- Maximum strength and hygiene
- Sharp edge transition improves floor seal integrity and hygiene
- Rounded corners reduce floor crack propagation



Big, deep drawn, smooth sided bowls

- Big 218 mm and 283 mm drain bowls provide superior hydraulic performance and lower maintenance
- Smooth sides and long radius transitions ensures maximum hygiene

Wide range of hygienic accessories

- Removable, easy to clean foul air traps, WaterMark
- Big basket capacities for less maintenance, shallow and deep options, 10mm, 6mm, 4mm and 2mm perforation options
- Tamper resistant outlet strainer options

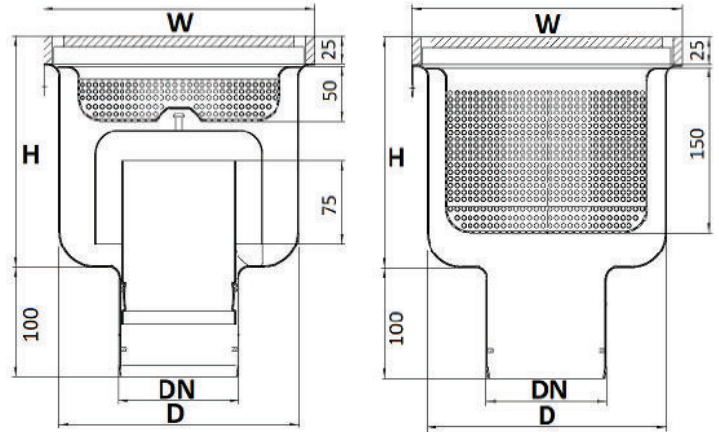

SHALLOW BASKET WITH TRAP

DEEP BASKET NO TRAP

STANDARD SQUARE TOP FLOOR DRAINS*

Item Code	DN (mm)	W (mm)	H (mm)	D (mm)
A-DRS-100-E-S	110	246	210	218
A-DRS-150-E-S	160	310	250	283

Grate/Cover Code	Drain Code	Type	Load Class	Slip Rating
A-SR-E-246	A-DRS-100-E-S	Bar	M125	R11
A-SR-RH-E-246		Bar Anti-Slip	M125	R12
A-GR-RH-E-246		Mesh Anti-Slip	L15	R12
A-HYG-E-246		Hygienic	N250	R10
A-P-E-246		Plate	M125	R10
A-SR-E-310	A-DRS-150-E-S	Bar	M125	R11
A-SR-RH-E-310		Bar Anti-Slip	R50	R12
A-GR-RH-E-310		Mesh Anti-Slip	L15	R12
A-HYG-E-310		Hygienic	N250	R10
A-P-E-310		Plate	M125	R10

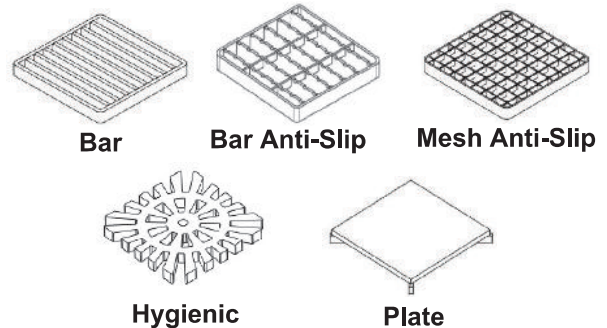

STANDARD ROUND TOP FLOOR DRAINS*

Item Code	DN (mm)	W (mm)	H (mm)	D (mm)
A-DRS-100-RD-S	110	270	210	218
A-DRS-150-RD-S	160	331	250	283

Grate/Cover Code	Drain Code	Type	Load Class	Slip Rating
A-SR-RDS-270	A-DRS-100-RDS-S	Bar	M125	R11
A-SR-RH-RDS-270		Bar Anti-Slip	M125	R12
A-GR-RH-RDS-270		Mesh Anti-Slip	L15	R12
A-HYG-RDS-270		Hygienic	N250	R10
A-P-RDS-270		Plate	M125	R10
A-PRD-270		Plate Sealed	M125	R10
A-SR-RDS-331	A-DRS-150-RD-S	Bar	M125	R11
A-SR-RH-RDS-331		Bar Anti-Slip	R50	R12
A-HYG-RDS-331		Hygienic	N250	R10
A-GR-RH-RDS-331		Mesh Anti-Slip	L15	R12
A-P-RDS-331		Plate	M125	R10
A-PRD-331		Plate Sealed	M125	R10

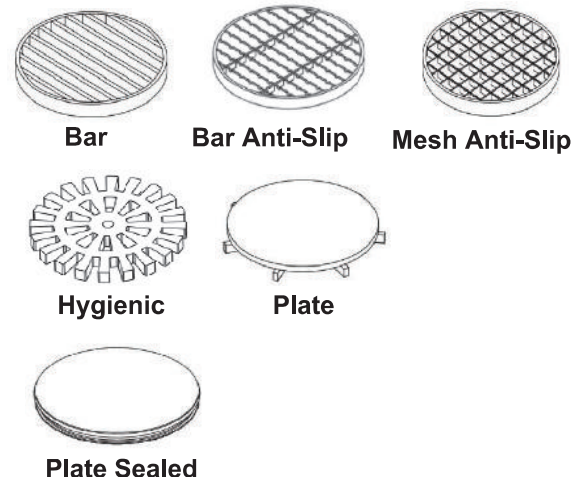

* Non-standard products are available and made-to-order, please contact OzFlow for further information

FLOOR DRAIN ACCESSORIES - BASKETS, TRAPS AND OUTLET STRAINERS

Item Code	Accessory Description	Drain Code	Important Notes
A-SF-218-10	Shallow Basket 10MM Perforations (50mm depth, capacity 1.33 litres)	A-DRS-100-E-S A-DRS-100-RD-S	Must use with Plug-In Trap
A-SF-218-4	Shallow Basket 4MM Perforations (50mm depth, capacity 1.33 litres)		Must use with Plug-In Trap
A-SF-218-2	Shallow Basket 2MM Perforations (50mm depth, capacity 1.33 litres)		Must use with Plug-In Trap
A-GVS-110	Plug-In Trap DN 110		Only use with Shallow Baskets
A-SFD-218-10	Deep Basket 10mm Perforation (150mm depth, capacity 4.0 litres)		Not compatible with Plug-In Trap
A-SFD-218-4	Deep Basket 4mm Perforation (150mm depth, capacity 4.0 litres)		Not compatible with Plug-In Trap
A-SFD-218-2	Deep Basket 2mm Perforation (150mm depth, capacity 4.0 litres)		Not compatible with Plug-In Trap
A-SBS-110-10	Outlet Strainer DN110 10MM Bolted		Only for DN 110 outlets
A-SBS-110-4	Outlet Strainer DN110 4MM Bolted		Only for DN 110 outlets
A-SBS-110-2	Outlet Strainer DN110 2MM Bolted		Only for DN 110 outlets
A-SF-283-10	Shallow Basket 10MM Perforations (50mm depth, capacity 2.32 litres)	A-DRS-150-E-S A-DRS-150-RD-S	Must use with Plug-In Trap
A-SF-283-4	Shallow Basket 4MM Perforations (50mm depth, capacity 2.32 litres)		Must use with Plug-In Trap
A-SF-283-2	Shallow Basket 2MM Perforations (50mm depth, capacity 2.32 litres)		Must use with Plug-In Trap
A-GVS-160	Plug-In Trap DN 160		Only use with Shallow Baskets
A-SFD-283-10	Deep Basket 10mm Perforation (150mm depth, capacity 7.0 litres)		Not compatible with Plug-In Trap
A-SFD-283-4	Deep Basket 4mm Perforation (150mm depth, capacity 7.0 litres)		Not compatible with Plug-In Trap
A-SFD-283-2	Deep Basket 2mm Perforation (150mm depth, capacity 7.0 litres)		Not compatible with Plug-In Trap
A-SBS-160-10	Outlet Strainer DN160 10MM Bolted		Only for DN 160 outlets
A-SBS-160-4	Outlet Strainer DN160 4MM Bolted		Only for DN 160 outlets
A-SBS-160-2	Outlet Strainer DN160 2MM Bolted		Only for DN 160 outlets
A-SFD-400-4	Basket 4mm perforations for A-75-400 (176mm depth, capacity 19.75 litres)	A-75-400-150-E-S	Must use with Plug-In Trap
A-SFD-400-2	Basket 2mm perforations for A-75-400 (176mm depth, capacity 19.75 litres)		Must use with Plug-In Trap
A-GVS-160	Plug-In Trap DN 160		Only for DN 160 outlets
A-SBS-160-10	Outlet Strainer DN160 10MM Bolted		Only for DN 160 outlets
A-SBS-160-4	Outlet Strainer DN160 4MM Bolted		Only for DN 160 outlets
A-SBS-160-2	Outlet Strainer DN160 2MM Bolted		Only for DN 160 outlets
A-SFD-600-4	Basket 4mm perforations for A-75-600 (176mm depth, capacity 50.0 litres)	A-75-600-200-E-S	Must use with Plug-In Trap
A-SFD-600-2	Basket 2mm perforations for A-75-600 (176mm depth, capacity 50.0 litres)		Must use with Plug-In Trap
A-GVS-200	Plug-In Trap DN 200		Only for DN 200 outlets
A-SBS-200-10	Outlet Strainer DN200 10MM Bolted		Only for DN 200 outlets
A-SBS-200-4	Outlet Strainer DN200 4MM Bolted		Only for DN 200 outlets
A-SBS-200-2	Outlet Strainer DN200 2MM Bolted		Only for DN 200 outlets

LARGE FLOOR DRAINS (MADE TO ORDER)

Welded square profile edge protection. Grate recess hygienically formed with side walls on all sides. Lockable, hinged stainless steel bar cover, optional foul air trap, large capacity strainer baskets and outlet strainers.

Item Code	DN (mm)	W (mm)	H (mm)	H1 (mm)	D (mm)
A-75-400-150-E-S	160	447	400	260	283
A-75-600-200-E-S	200	647	400	260	356

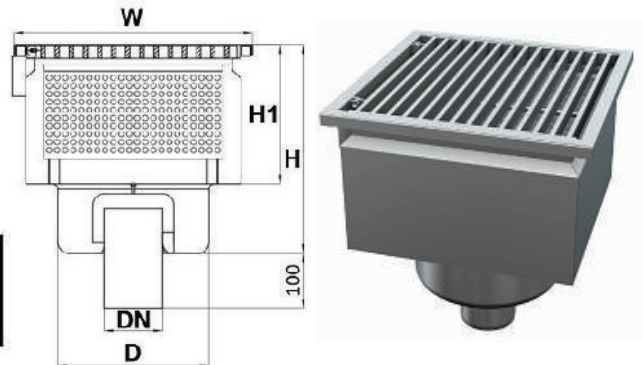

FLOOR DRAIN NOMINAL FLOW RATES

Floor Drain Product (Body/Outlet)	Outlet Size	Option 1	Option 2	Option 3	Option 4
A-DRS-100 (218/110)	110mm	5.35 l/s	4.13 l/s	4.48 l/s	3.3 l/s
A-DRS-150 (283/160)	160mm	12.32 l/s	9.00 l/s	9.93 l/s	6.60 l/s
A-75-400-150 (283/160)	160mm	13.55 l/s	9.90 l/s	10.92 l/s	7.26 l/s
A-75-600-200 (356/200)	200mm	15.51 l/s	11.32 l/s	12.50 l/s	8.31 l/s

Option 1 - Bar Grate & Deep Filter Basket (4mm perf) Installed. No Secondary Strainer Screen or trap.

Option 2 - Bar Grate, Deep Filter Basket (4mm perf) & Secondary Strainer Screen (4mm perf) Installed. No trap.

Option 3 - Bar Grate, Shallow Filter Basket (4mm perf) & Removable Water Trap Installed. No Secondary Strainer Screen.

Option 4 - Bar Grate, Shallow Filter Basket (4mm perf), Removable Water Trap and Secondary Strainer Screen (4mm perf) Installed.

INSPECTION POINTS

Plate cover 10mm, M125, bolted, sealed, item code **A-PRD-V**

Item Code	Cover Shape	DN (mm)	W (mm)	H (mm)
A-REV-100-RD-S	Round	110	218	199
A-RFV-150-RD-S	Round	160	218	208

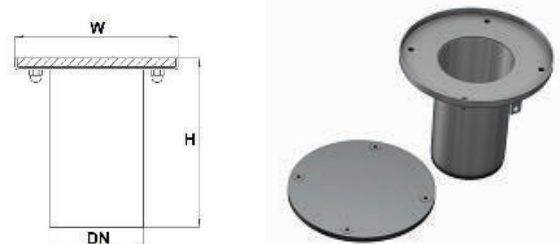

INDUSTRIAL DRAINAGE CHANNELS

- Stainless steel reinforced channel edges as standard, hygienic, strong and durable
- Channels from 150mm up to 500mm standard widths
- A range of grates and covers including bar, anti-slip, plate and ultra hygienic and super strong laser cut billet stainless grates
- Efficient and hygienic V-profile and also U-profile for greater capacity
- Anchor tags every 500mm
- Adjustable levelling feet every 1000mm
- Fall built-in, standard 0.6%
- Easy, flanged/bolted, weld-free assembly on site eliminates hot works
- Custom made for each project with short lead times



V-PROFILE CHANNELS WITH GRATES/COVERS

ITEM	W	P	AT
A-GKR-150	150	70	60
A-GKR-200	200	120	60
A-GKR-250	250	170	60
A-GKR-300	300	220	60
A-GKR-400	400	320	60
A-GKR-500	500	420	60

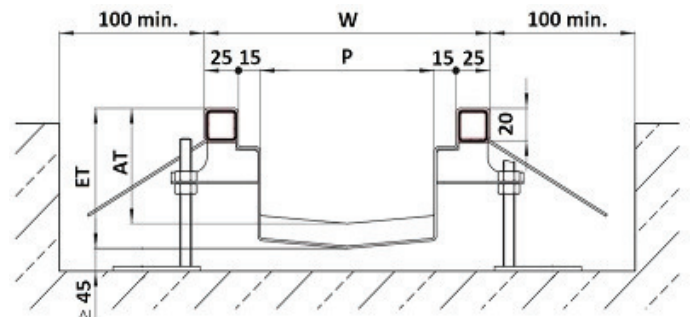

U-PROFILE CHANNELS WITH GRATES/COVERS

ITEM	W	P	AT
A-RPR-G-150	150	70	80
A-RPR-G-200	200	120	100
A-RPR-G-250	250	170	130
A-RPR-G-300	300	220	155
A-RPR-G-400	400	320	205
A-RPR-G-500	500	420	255

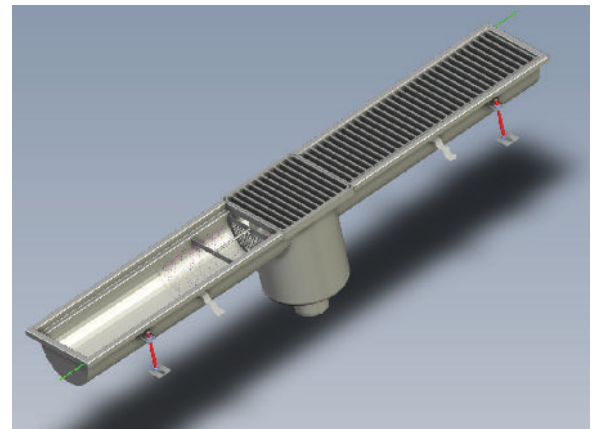

CHANNEL GRATES AND COVERS

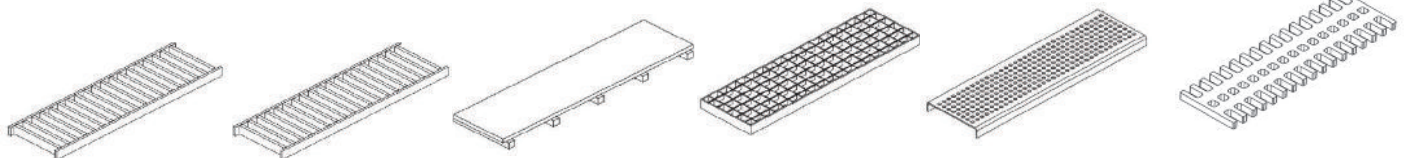

Bar

Bar Anti-Slip

Plate

Mesh Anti-Slip

Perforated Sheet

Hygienic

A-SR-150
A-SR-200
A-SR-250
A-SR-300
A-SR-400
A-SR-500

A-SR-RH-150
A-SR-RH-200
A-SR-RH-250
A-SR-RH-300
A-SR-RH-400
A-SR-RH-500

A-P-150
A-P-200
A-P-250
A-P-300
A-P-400
A-P-500

A-GR-RH-150
A-GR-RH-200
A-GR-RH-250
A-GR-RH-300
A-GR-RH-400
A-GR-RH-500

A-LB-150
A-LB-200
A-LB-250

A-HYG-150
A-HYG-200
A-HYG-250
A-HYG-300
A-HYG-400
A-HYG-500

SLOT CHANNEL A-SRD-70

- Grate-free, cost-effective, easy maintenance and improved safety
- Stainless steel reinforced channel edges as standard, hygienic, strong and durable
- Efficient and hygienic V-profile
- Can be connected to any OzFlow floor drain, or custom outlet
- Anchor tags every 500mm
- Adjustable levelling feet every 1000mm
- Fall built-in, 0.6% standard
- Easy, flanged/bolted, weld-free assembly on site eliminates hot works
Custom made for each project with short lead times

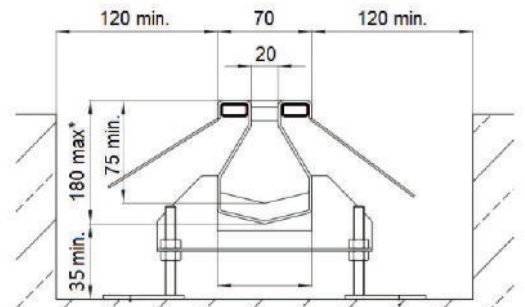
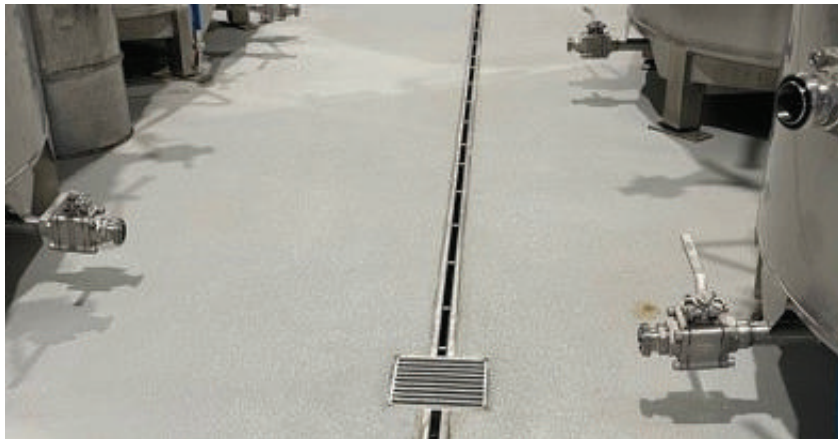

* Non-standard products available, please contact OzFlow

CHANNEL OUTLETS

Item	Outlet DN (mm)	Outlet Drain Body Diameter (mm)	Outlet Drain Top Size (mm)
A-SRD-70	110	218	246 x 246
A-SRD-70	160	283	310 x 310
A-GKR-150	110	218	246 x 246
A-GKR-150	160	283	310 x 310
A-GKR-200	110	218	246 x 246
A-GKR-200	160	283	310 x 310
A-GKR-250	110	218	246 x 246
A-GKR-250	160	283	310 x 310
A-GKR-300	110	218	Integrated
A-GKR-300	160	283	310 x 310
A-GKR-400	110	218	Integrated
A-GKR-400	160	283	Integrated
A-GKR-500	110	218	Integrated
A-GKR-500	160	283	Integrated



OPTIONAL CHANNEL EDGE DETAILS

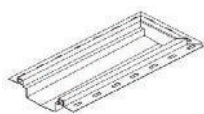

Perforated Flange

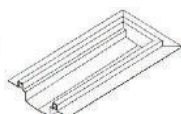

Flange

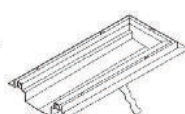

Tiling Flange



DESIGN & INSTALLATION

Channels are typically manufactured in sections up to 4 metres in length to facilitate transportation and safe, manageable handling on site. Channels longer than 4 metres generally have bolted flange connections requiring assembly on site.

As a general rule, channels should be no longer than 10 metres in length per outlet.

When designing and planning the installation, allow clearances for anchor tabs, levelling feet and connection flanges (for channels) in the cut out for the drain/channel. Connection flanges extend approximately 45 mm below the drain invert.

All channel components are individually marked to allow for easy installation.

1. Check the required final floor height and ensure pipe connections are at the desired height
2. For channels with flange connections, bolt flanges together ensuring the provided gaskets are in place to provide a watertight seal.
3. Place the floor drain/channel into position, taking care to insert the drain outlet securely to the pipe connection. Rubber shoes are provided on the levelling feet for installation on waterproof membranes.
4. Bend anchor tabs outwards 90 degrees from the floor drain/channel for keying into the concrete.
5. Set the floor drain/channel height using adjustable threaded rods/levelling feet as required, or use a small amount of concrete to fix the floor drain in position. The drain/channel top surface should be 1 to 1.5 mm below the desired finished floor level, also allowing for epoxy or other surface finish.
6. For installations without waterproof membrane the levelling feet may be secured to the floor by drilling and bolting, alternatively, carefully weigh down the drain/channel to prevent movement of flotation during the concrete pour
7. Install expansion joint detail around the perimeter of the drain/channel as per design requirements.
8. Cover the drain/channel to prevent debris entering the drain/channel or the drainage system.
9. Pour concrete, ensuring concrete is fully supporting the drain/channel
10. Seal around the floor drain/channel as per designer requirements
11. At completion of the project construction phase, clean the drain/channels and install accessories, traps, baskets, grates/covers.

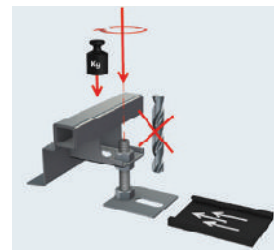
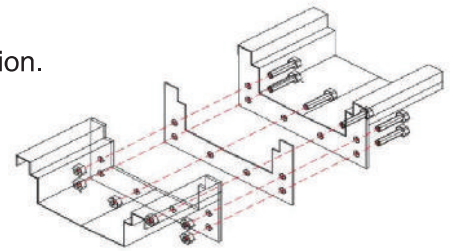

Installation on waterproof membrane

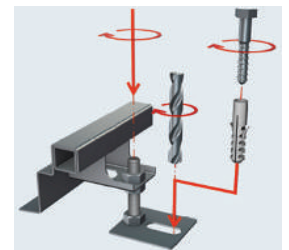

Installation without waterproof membrane

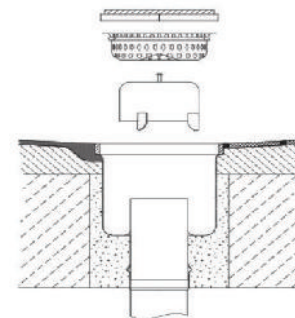
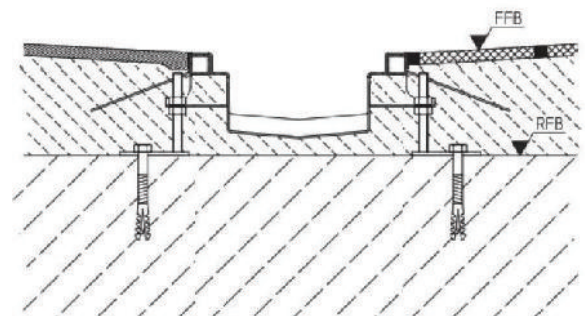



OzFlow

**Stainless Steel Industrial
Floor Drains & Channels**

www.ozflow.com.au

Email info@ozflow.com.au

P (07) 3273 6847

International +61 7 3273 6847

P.O. Box 1571
Sunnybank Hills QLD 4109
Australia

VER. 04/2024